

OPAL-RT's Solution for **Hybrid** EMT-TS Simulation

Contents

- Why EMT-PHASOR Hybrid Methods?
- Real-time simulation tools
- Hybrid simulation environment
- Radial distribution test case
- Transmission test case
- Limitations and proposed method for practical cases

Why EMT-PHASOR Hybrid Method?

Hybrid simulation is a research subjects since more than 30 years for the following reasons!

- **Cost and Capability of EMT real-time simulator**
 - To enable EMT real-time simulation of very large power grid at minimum cost
 - or simply to perform large-scale simulation with analog or real-time digital simulators having limited capability
- **Increase accuracy of phasor-domain simulation**
 - Simulation and fast HVDC and FACTS subsystems and controller may be unknown for unbalanced conditions
 - Effects of low-frequency resonances, harmonics on control and protection while simulating a very large system
- **Reduction of computing time and increase accuracy of EMT simulation**
 - Simulating some subsystems in EMT mode but having a good simulation of the dynamic behavior of the very large system

Real-time simulation tools - Overview

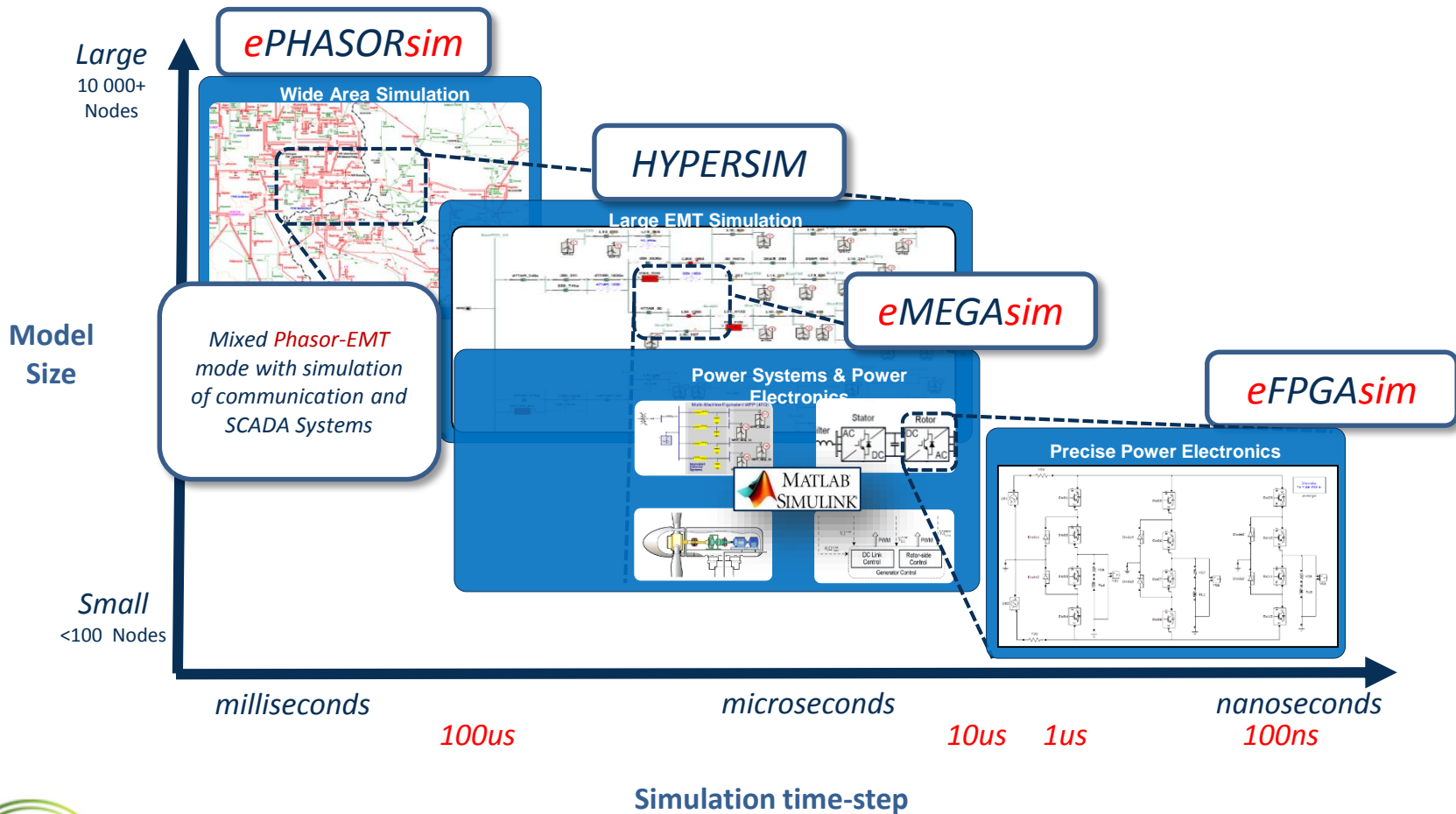

Real-time simulation tools - Performance

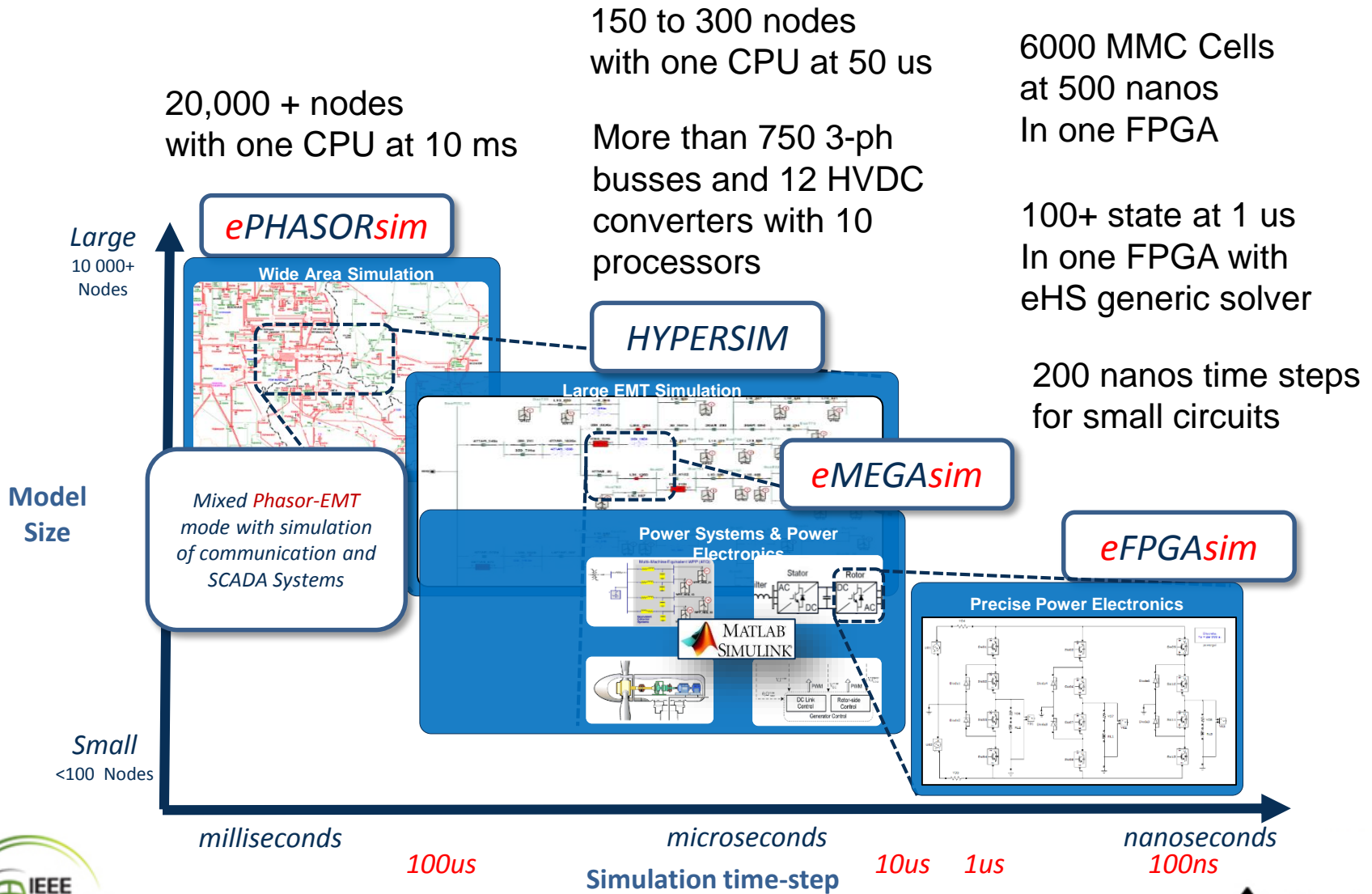

Hybrid EMT-TS Simulation

RT-LAB suits provides simulation environment that facilitates to:

- Run two types of simulations in **one working model**
- Develop, test, and validate various **interaction protocols** between TS and EMT domains
- Examine strategies to choose the **domain of study** and **interface location** between TS and EMT domains
- Choose the **interface variables** that need to be exchanged between two domains

Distribution Radial system test case

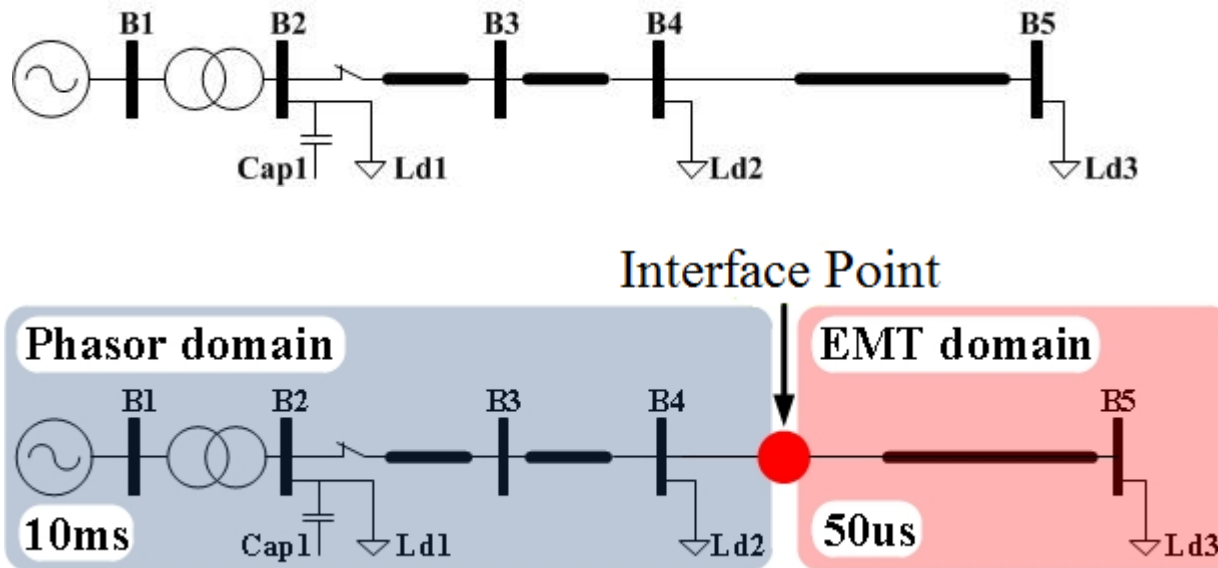

Distribution system test case

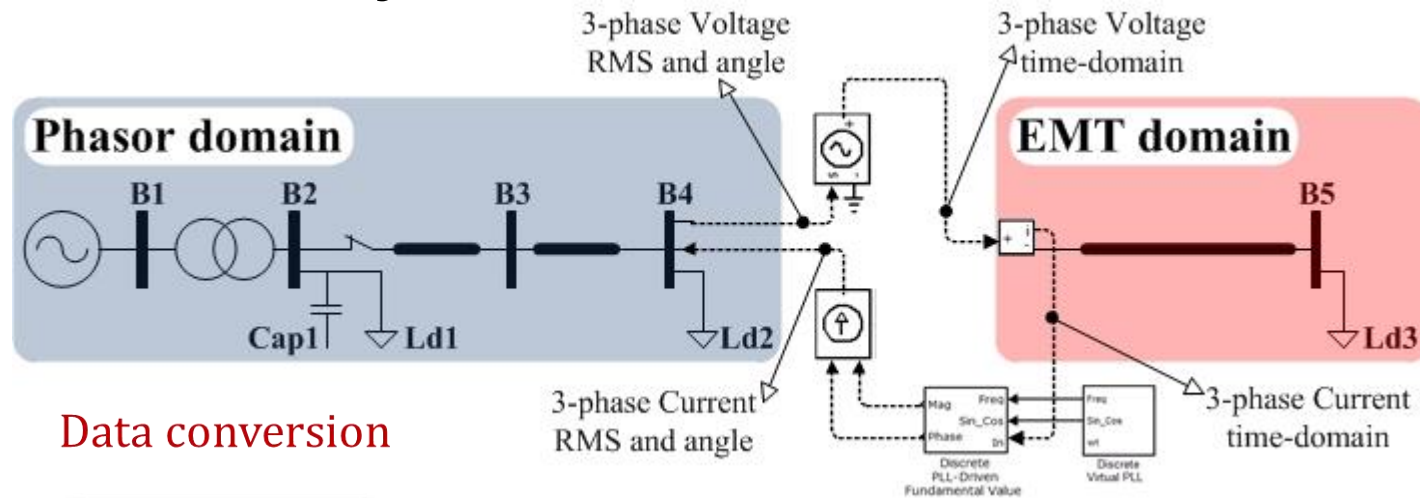

Data conversion

Interaction protocol

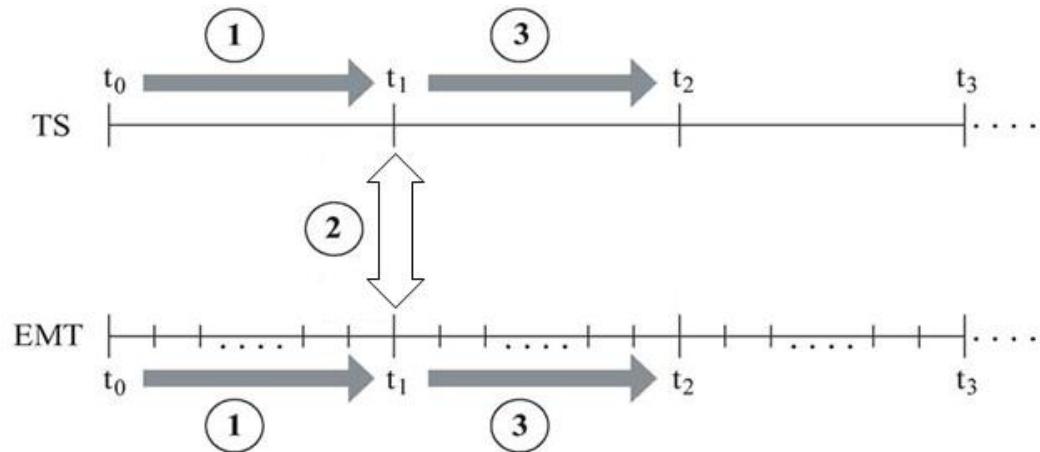
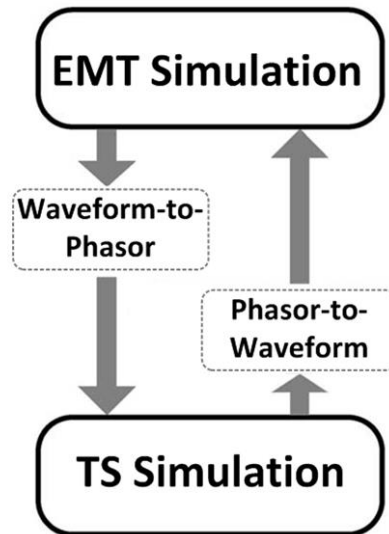

Fault in EMT domain

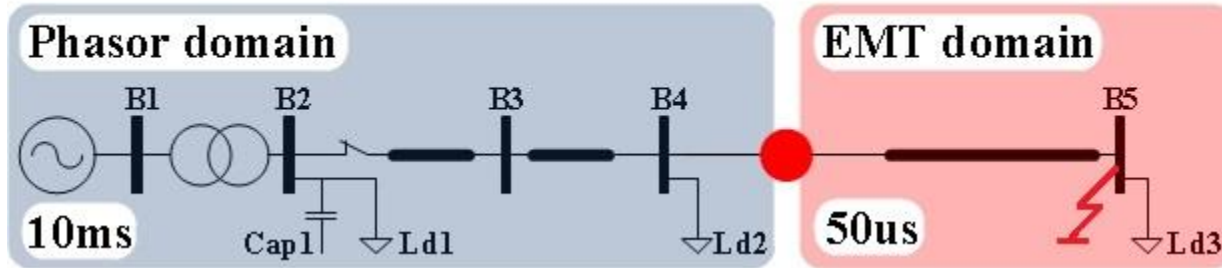

Measurements in EMT domain: V_{B5} , I_{B4_B5}

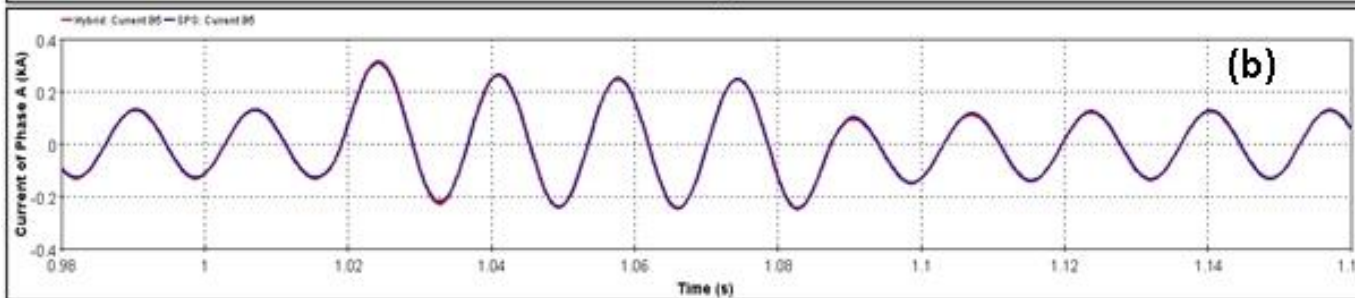
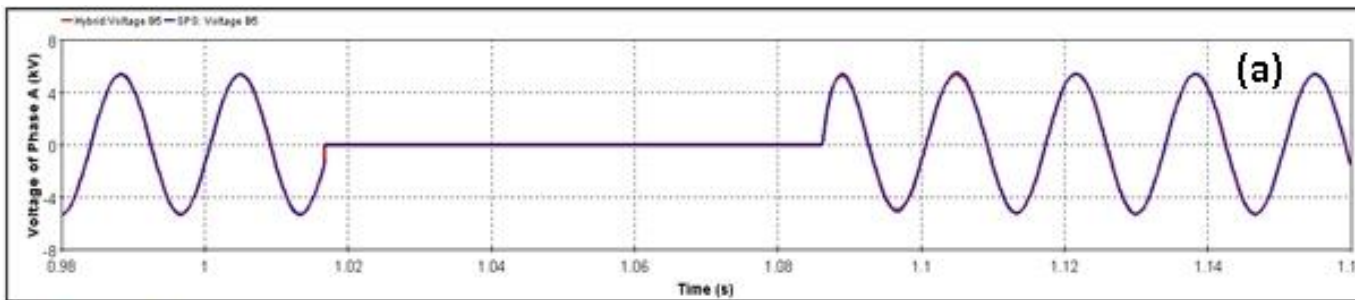

Fault in Phasor domain

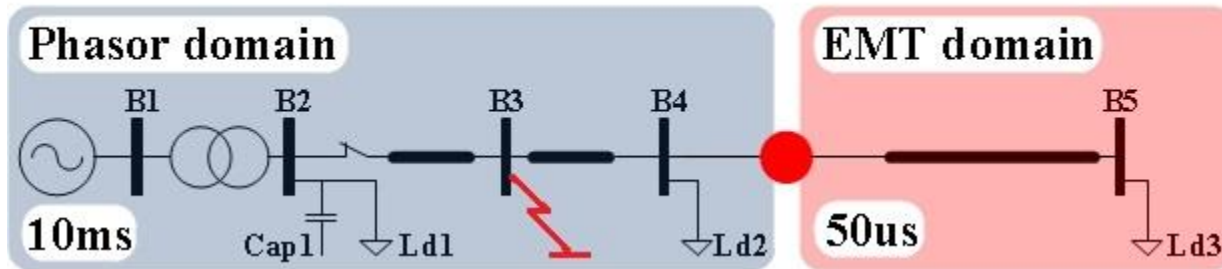

Measurements in EMT domain: V_{B5} , I_{B4_B5}

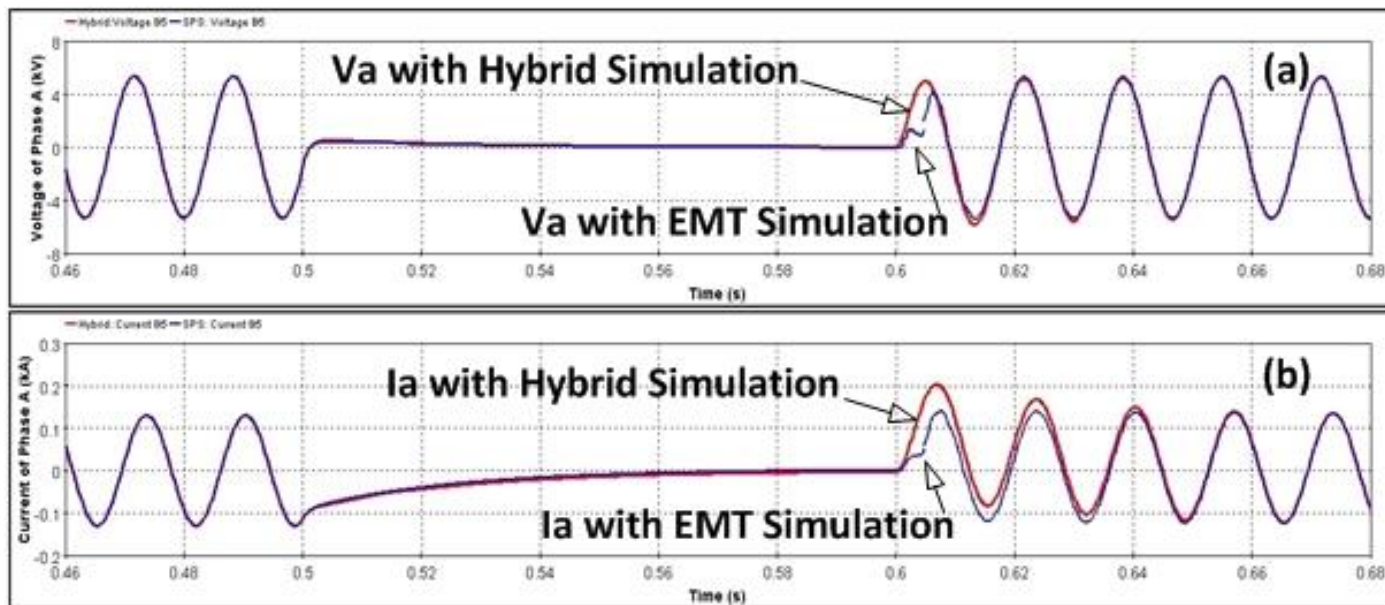

Fault in EMT Domain

Voltage at Bus 9

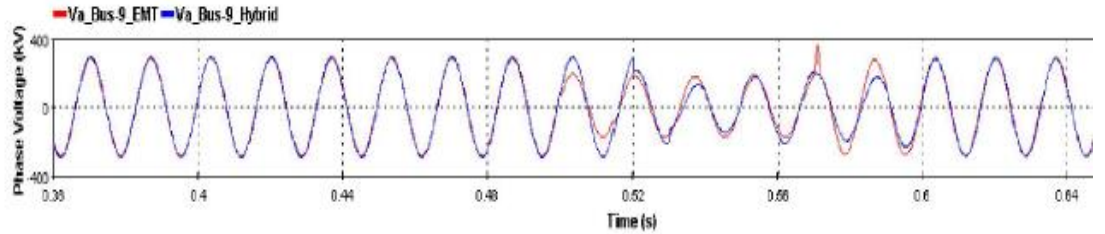

Voltage at WT Terminal

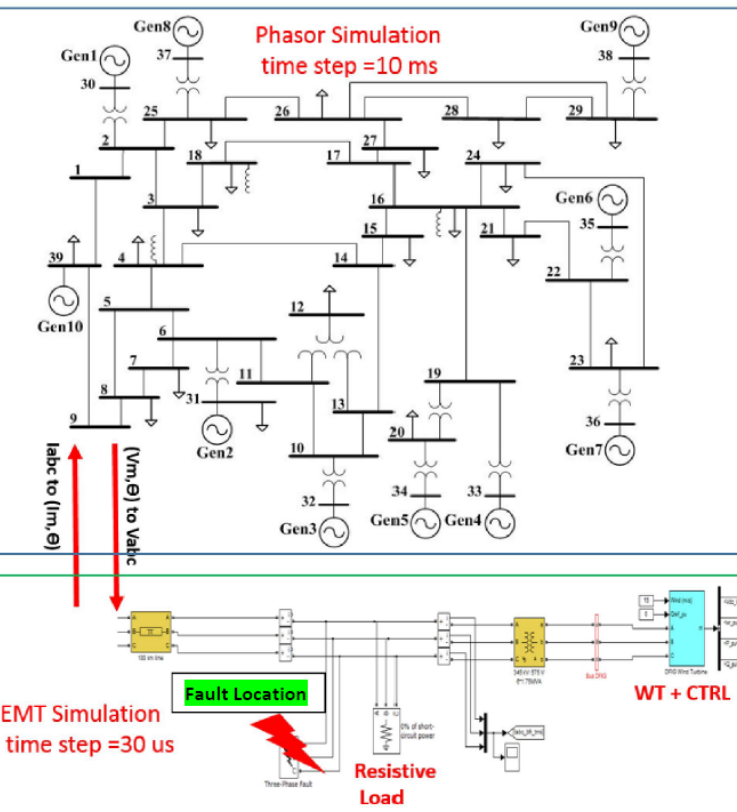
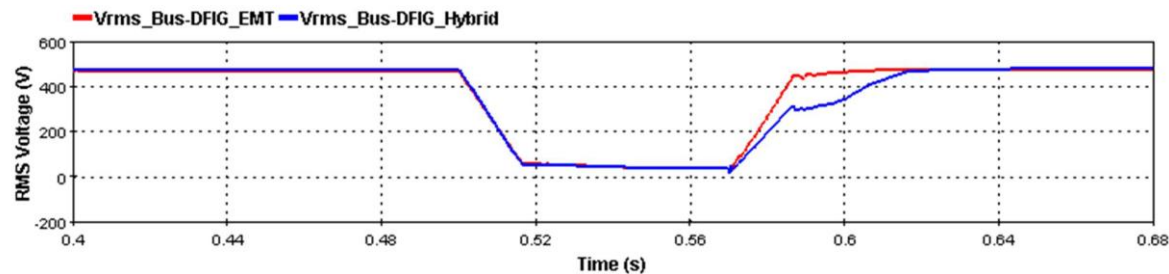
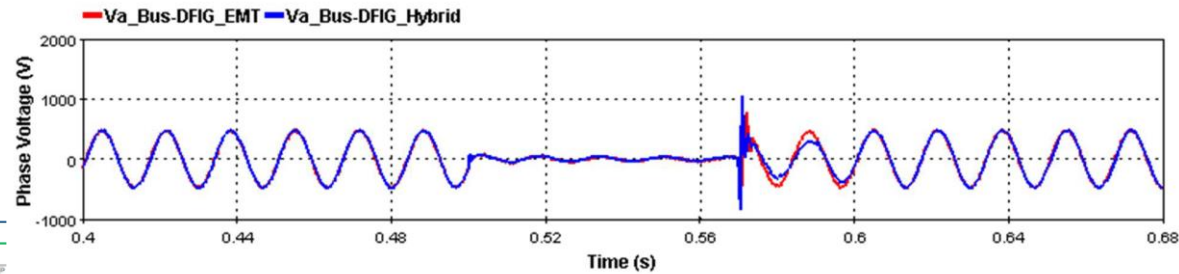

Fault in PHASOR Domain

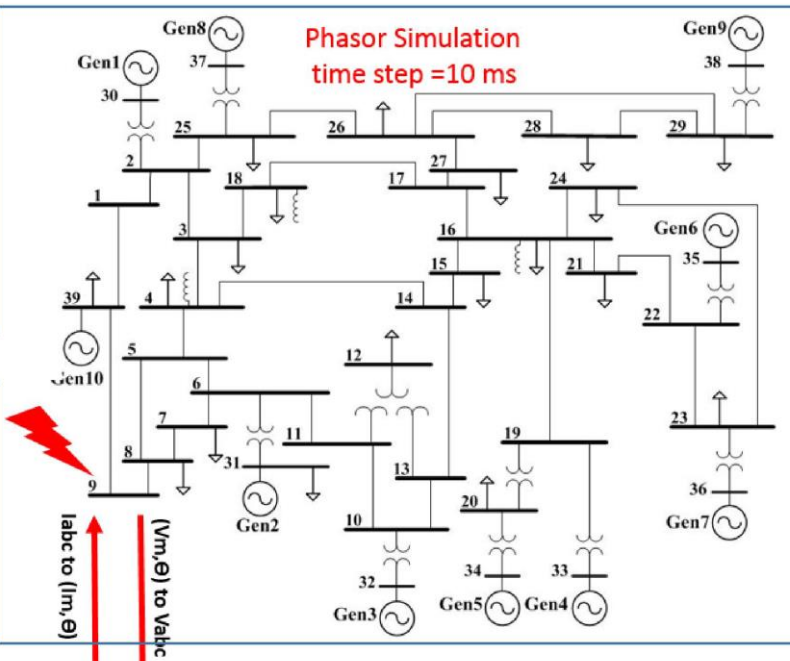

Voltage at Bus 9

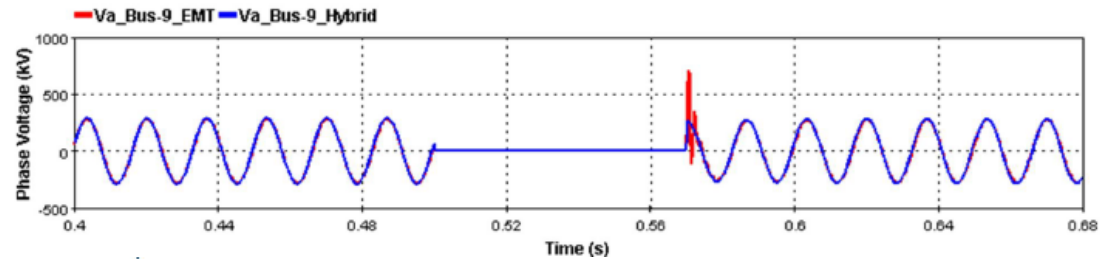

Voltage at WT Terminal

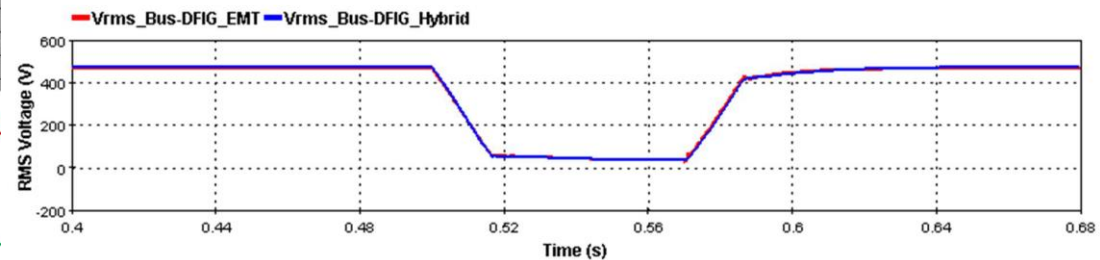
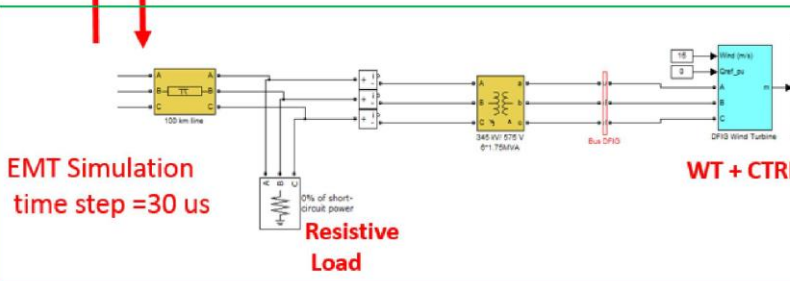
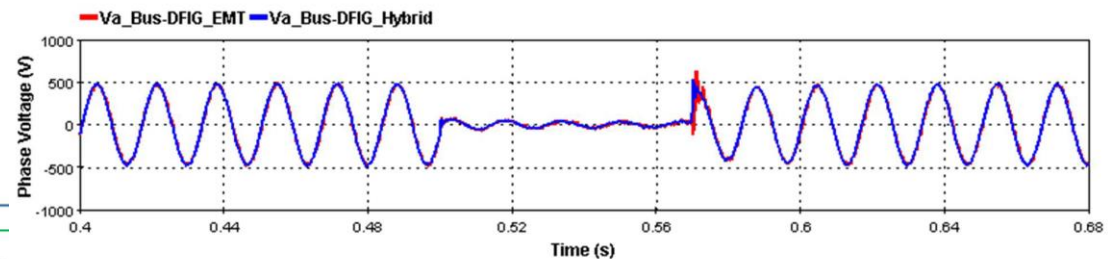

Limitation of the method presented

- The method used in this study consists of representing one large part of the transmission system in phasor mode and a part of the load, including a wind park in EMT model with **a very simple coupling method**.
- Such method is adequate only when the impedance of the subsystem simulated in phasor model **DOES NOT exhibit resonances at low frequency** in the range of DC to about 200 Hz. This is typically the case for low-voltage network without long-lines and series capacitors
- Such technique cannot adequately represent the dynamics of networks with long lines and series capacitor simulated in phasor mode.
- One of the main objectives of simulating complex control systems, like FACTS, HVDC and Wind turbine, in EMT mode is specifically to verify that these control systems are not affected by low frequency resonances.
- The second objective is to implement corrective means in the controllers if bad performance and instability are detected.
- However, if the AC network with long lines is represented in phasor mode, such equivalent will eliminate all low-frequency resonances and we will have unrealistic results i.e. the controllers of these complex devices (e.g. HVDC) will have an ideal and un realistic responses.

Recommendations for networks with long lines and series capacitors

- **Method 1: Frequency Dependent Equivalent Network at the Point of Common Coupling**
 - This method requires to compute the multi-node frequency Thevenin equivalent as seen from each node of the EMT subsystem including the mutual impedances between each node
 - This frequency dependent equivalent must be recomputed each time there is a fault or a modification of the topology of the sub-system simulated in phasor mode
 - The frequency bandwidth and the accuracy of the network equivalent must be good enough to achieve the project goal.
 - The amplitude and angle of all Thevenin voltages must be adjusted to obtain the good power flow
 - The Frequency dependent network impedance must be simulated on the EMT subsystem using state space method or network synthesis (R-L-C branches)

In summary, this method is very complex and does not easily allow to analyse the effects of faults occurring in the network subsystem simulated in phasor mode

Recommendations for networks with long lines and series capacitors

- **Method 2: Simulation of the high-voltage subsystem in EMT mode and low voltage subsystems and load in phasor domain**
 - This method assumes that
 - the low-frequency poles and zeros as seen from the common point of coupling are mainly created by very long transmission line, with or without series capacitors, connected to generator
 - The low-voltage circuits and loads will have little effects on low frequency poles and zero for the most severe contingency because of the effect of coupling transformers and the fact that low-voltage lines are usually short.
 - The low-voltage Thevenin equivalent could be computed for the fundamental frequency and represent as a series R-L circuit with a parallel resistor across the resistance to represent the damping
 - The accuracy can be estimated by comparing the impedance versus frequency obtained with the full system and with the hybrid model. Transient test results can also be performed with the full EMT model, full phasor-mode model and with the hybrid models

Recommendations for networks with long lines and series capacitors

- **Method 2: Simulation of the high-voltage subsystem in EMT mode and low voltage subsystems and load in phasor domain**
 - This method is much more simpler to implement and more flexible than method 1 because:
 - The low-voltage Thevenin equivalent could be computed for the fundamental frequency and represent as a series R-L circuit with a parallel resistor across the resistance to represent the damping
 - Modern real-time and off-line parallel EMT simulators and programs can simulate power grid with up to 50 to 100 three-phase buses and hundreds of transmission line in real-time or faster than real-time at 50 micros in only one processor
 - The processing time required to simulate a typical transmission system using Bergeron-Type transmission lines may be smaller than the time to simulate a complex network equivalent using state-space method or equivalent network
 - The processing time consumed to simulate large and complex low-voltage network with short-line is eliminated

Recommendations for networks with long lines and series capacitors

- **Method 2: Simulation of the high-voltage subsystem in EMT mode and low voltage subsystems and load in phasor domain**

In summary, this method is very simple and practical because

- ❑ Low-Frequency resonances are preserved, which is essential for fast control and protection system testing in more detailed allowed by using only phasor-mode simulation
- ❑ Any types of unbalanced fault and disturbances can be apply anywhere on the EMT subsystem without the need to re-compute the frequency-dependent equivalent as required by method 1.
- ❑ No complex frequency-dependent equivalent method is required
- ❑ The processing power required to simulated a large transmission system with more than 50 high-voltage stations, 100 transmission lines, transformers and generators with a frequency range up to 2,000 Hz may be smaller than simulating a large state-space equivalent network.
- ❑ The global processing power or simulation time is reduced by eliminating the simulation of hundreds of circuit element of low-voltage subsystems, which is ne of the main objective of hybrid EMT-Phasor simulation.

Conclusions

- Hybrid EMT-Phasor domains simulation method is still required for the accurate simulation of very large power grid including several HVDC and FACTS devices having controllers and protection models not fully validated for average phasor domain simulation under balanced and **unbalanced** conditions
 - It ease easier and more practical to simulate the high-voltage grid with long transmission line in the EMT subsystems and the low-voltage sub-system with a simple equivalent in Phasor mode
 - The capability of modern real-time simulators and EMT off-line software make the use of the hybrid method less critical than 20 years ago
- **Hybrid EMT-Phasor simulation is still an R&D subject matter. Collaborators are welcome!**